

PDI BALL ARBORS & CHUCKS

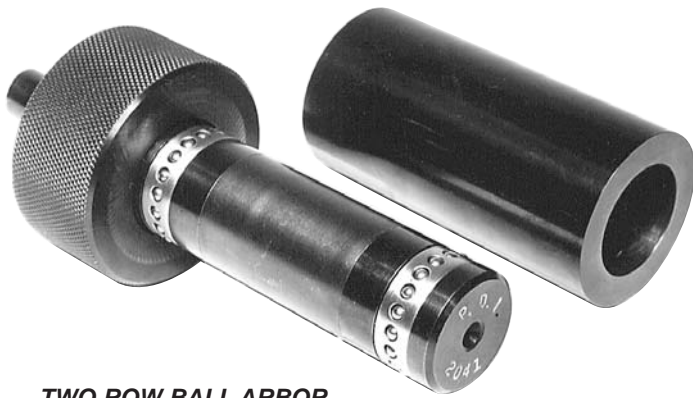

PRECISION DEVICES, INC.



TWO ROW BALL ARBOR WITH RUNOUT MASTER

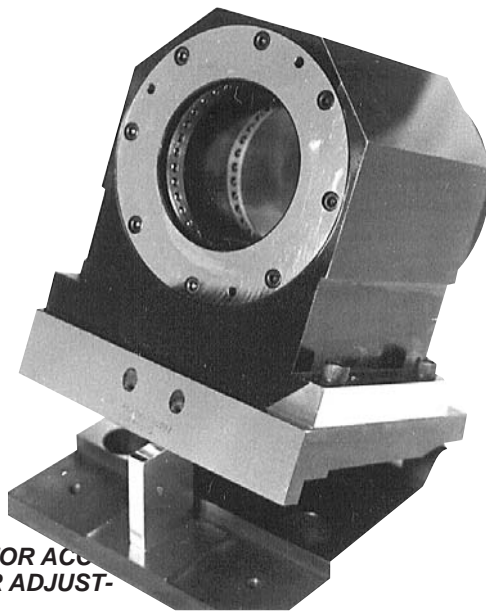

BALL CHUCK MOUNTED ON A SINE PLATE FOR ACCURATE ANGULAR ADJUSTMENT

BALL ARBORS

PDI Ball Arbors are used primarily to position parts for inspection of runout, concentricity, squareness and parallelism. Parts may be straight or tapered, plain or serrated, full circumference or segmented. Ball arbors are often used to solve difficult gaging problems, such as center distance gaging, true hole positioning and checking the requirements of geometric tolerancing.

BALL CHUCKS

PDI Ball Chucks employ the same exclusive ball-ring principle as the ball arbors, and are used to locate O.D.s from .156" to 16". As with our ball arbors, ball chucks are used primarily to inspect parts for runout, concentricity, squareness and parallelism.

CUSTOM BUILT

PDI Ball Arbors and Chucks are all custom designed and built to each customer's application. In addition, PDI has the capability to provide complete inspection packages, including arbors/chucks and all associated fixturing to meet your exact gaging requirements.

APPLICATIONS

TWO ROW BALL ARBOR WITH NUT FOR MEASURING GEAR CHARACTERISTICS

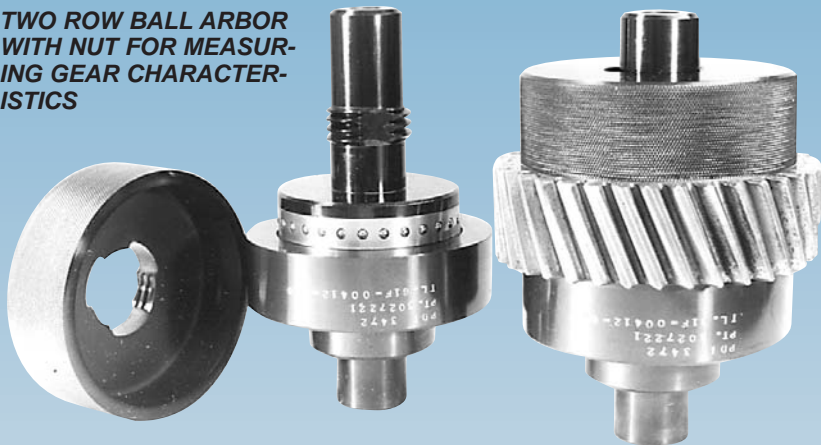

CENTERLINE AXIS ESTABLISHED BY TWO ROW BALL ARBOR ON DIFFERENT PARAMETERS

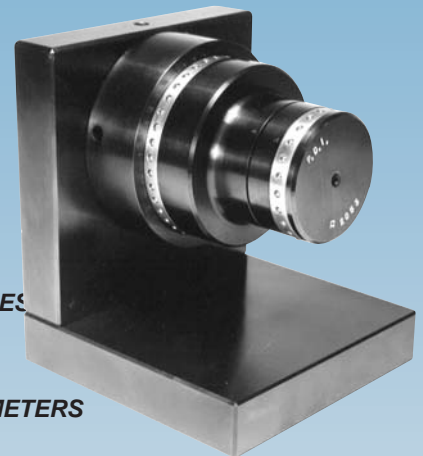

THE BALL-RING PRINCIPLE

The key to many of the features of PDI Arbors and Chucks lies in the circle of precision balls that contact the part. Seated in an expandable raceway, the balls firmly contact the part, establish and maintain its true axis, and still allow it to rotate freely. The workpiece I.D. or O.D. is always centered, regardless of slight variations in diameter, roundness or taper.

PDI Ball Arbors and Chucks are virtually indestructible. The precision balls are made of hardened steel and the faces that form the V-grooves are hardened, ground and lapped. Ball wear is compensated for by self-rounding. These devices will do their jobs and maintain their accuracy through many years of constant use.



ADVANTAGES

- Accurately establishes axis I.D. or O.D. up to .000050"
- Does not distort part
- Provides means of measuring runout, concentricity, squareness or parallelism
- Wide range of expansion, with no loss of accuracy
- Free rotation of part on arbor
- Unaffected by taper or out-of-round
- Will hold on interrupted surfaces
- Self-actuating
- Easily adapted to existing gages
- Antifriction feature contributes to long wear life



*BALL ARBORS WITH
WOBBLE WASHERS
TO CLAMP PART AND
NOT INFLUENCE
PART POSITION*

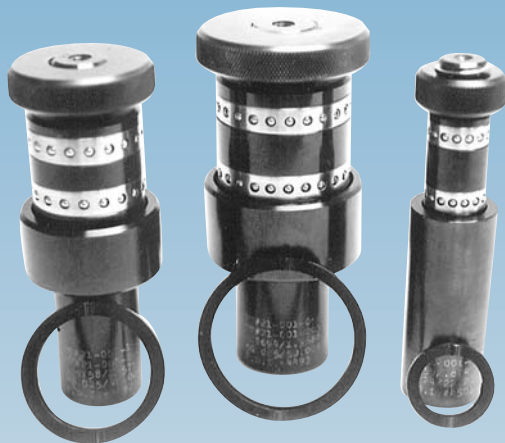

*BALL ARBOR
SWEEP GAGES*

FIXTURES AND GAGES

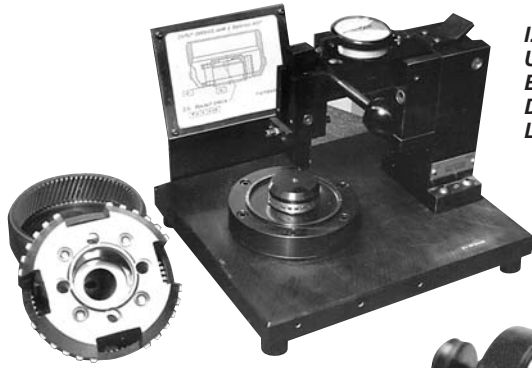

**I.D. RUNOUT GAGE
USING SINGLE ROW
BALL ARBOR &
DATUM FACE FOR
LOCATING**

**MULTIPLE CON-
CENTRICITY AND
SQUARENESS MEA-
SUREMENTS FROM
A SINGLE FIXTURING**

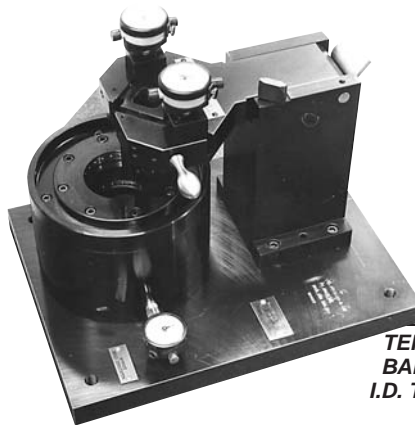
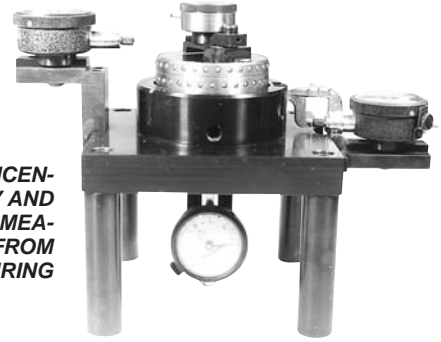

**BALL
ARBOR INDICATOR
SWEEP GAGE
FOR MEASURING
COUNTERBORE
RUNOUT**

ESTABLISHING THE CENTERLINE WITH A TWO ROW BALL CHUCK TO MEASURE I.D. TO O.D. CONCENTRICITY

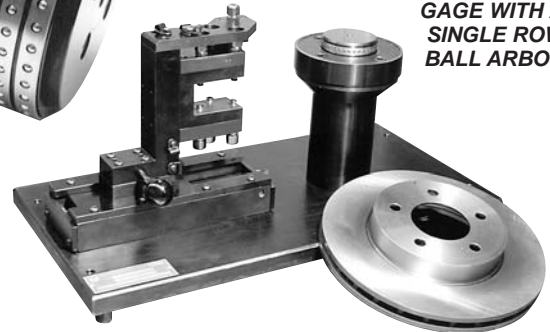

**FLANGE RUNOUT AND
THICKNESS VARIATION
GAGE WITH A
SINGLE ROW
BALL ARBOR**

OTHER PRECISION DEVICES PRODUCTS



**SURFOMETER® SURFACE ROUGHNESS
AND PROFILE MEASURING SYSTEMS**



**PDI CHAMPION® MANDRELS AND
WORK-HOLDING DEVICES**



PRECISION DEVICES, INC.
606 County Street, PO Box 220, Milan, MI 48160-0220
PHONE: (734) 439-2462 FAX: (734) 439-1461
Email: sales@predev.com Web: www.predev.com