

PDI/CHAMPION[®]



MANDRELS AND WORK-HOLDING DEVICES



C-M Heavy Duty Mandrels

Popular for inspection, grinding and turning operations in maintenance, prototype and tooling shops. Initial cost low; delivery fast; largest sleeve sizes commercially available. Proven, rugged, simple design.

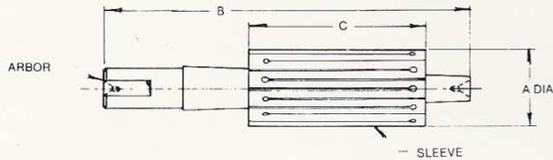

C-M-8 Mandrel

.001" T.I.R. Mandrel No. C-M	A Expansion	B	C	Sleeve Expansion			Total Weight
				Small	Medium	Large	
1	1/2-9/16"	5"	2 1/2"	1/2-9/16"	—	—	1/2 lb.
2	9/16-21/32"	6"	2 3/4"	9/16-21/32"	—	—	3/4 lb.
3	21/32-3/4"	6"	2 3/4"	21/32-3/4"	—	—	3/4 lb.
4	3/4-7/8"	7"	3 1/4"	3/4-7/8"	—	—	1 1/4 lb.
5	7/8-1"	7"	3 1/4"	7/8-1"	—	—	1 1/2 lb.
6	1-1 3/8"	9"	4"	1-1 3/16"	1 3/16-1 3/8"	—	3 lb.
7	1 1/4-1 5/8"	9"	4"	1 1/4-1 7/16"	1 7/16-1 5/8"	—	4 lb.
8	1 1/2-2"	11 1/2"	5"	1 1/2-1 3/4"	1 3/4-2"	—	7 lb.
9	2-2 3/4"	14 1/2"	5 1/2"	2-2 3/8"	2 3/8-2 3/4"	—	15 lb.
10	2 3/4-3 3/4"	17"	6"	2 3/4-3 1/4"	3 1/4-3 3/4"	—	32 lb.
11	3 3/4-5"	20"	7"	3 3/4-4 3/8"	4 3/8-5"	—	78 lb.
12	5-6 1/2"	24"	8"	5-5 3/4"	5 3/4-6 1/2"	—	148 lb.

C-M-600 Close Tolerance Mandrels

Popular for grinding, inspection and closer tolerance turning operations. Between center mounting. Two sleeve lengths available.

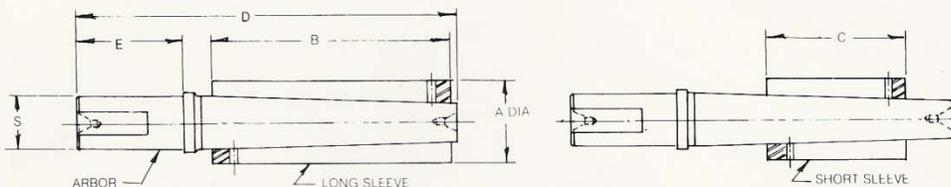

C-M-614 Mandrel with short sleeve

.0005" T.I.R. Mandrel No. C-M	.015" Sleeve Expansion A	ORDERING REQUIREMENTS:		D	E	S	Total Weight
		B Long	C Short				
614	7/8-1"	3 1/4"	1 5/8"	6 1/8"	2 5/16"	1 1/16"	3/4 lb.
615	1-1 1/4"	4"	2"	7"	2 3/8"	7/8"	1 3/4 lb.
616	1 1/4-1 1/2"	4"	2"	7"	2 3/8"	1"	2 1/2 lb.
617	1 1/2-1 15/16"	5"	2 1/2"	8"	2 3/8"	1 1/8"	4 1/4 lb.
618	1 15/16-2 7/16"	5 1/2"	2 3/4"	8 1/2"	2 3/8"	1 5/8"	7 3/4 lb.
619	2 7/16-3 3/8"	6"	3"	9"	2 3/8"	2 1/8"	14 1/4 lb.
620	3 3/8-5"	7"	3 1/2"	11"	3 1/8"	3"	34 1/2 lb.



C-N-100 Nut Actuated Mandrels

A nut-actuated, between center mandrel designed to simplify part loading/unloading, while providing the longest sleeve for maximum bore contact. Snap ring groove provides part locator stop. Excellent for those production requirements where .0005" T.I.R. is needed.

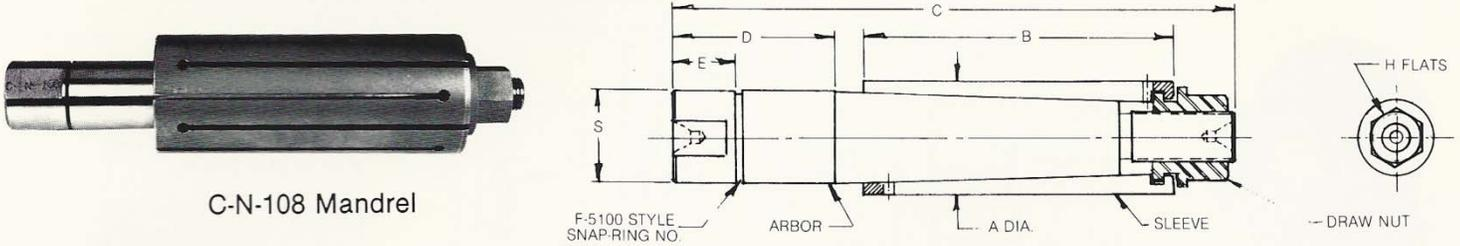

C-N-108 Mandrel

.0005" T.I.R.	.015" Sleeve Expansion	ORDERING REQUIREMENTS: Specify bore diameter and tolerance							
Mandrel No. C-N	A	B	C	D	E	F	H	S	Total Weight
103	5/8-3/4"	2 3/4"	5 3/16"	1 9/16"	1"	-50	7/16"	.510	1/2 lb.
104	3/4-7/8"	3 1/4"	5 13/16"	1 11/16"	1"	-59	7/16"	.605	3/4 lb.
105	7/8-1"	3 1/4"	6"	1 3/4"	1"	-68	1/2"	.703	1 lb.
106	1-1 1/4"	4"	7"	1 15/16"	1"	-87	9/16"	.843	1 1/2 lb.
107	1 1/4-1 1/2"	4"	7 3/16"	2 1/16"	1"	-93	11/16"	.968	2 1/4 lb.
108	1 1/2-2"	5"	8 7/16"	2 3/16"	1"	-112	7/8"	1.155	4 1/2 lb.
109	2-2 3/4"	5 1/2"	9 15/16"	2 7/8"	1 1/8"	-162	1 5/16"	1.624	9 lb.
110	2 3/4-3 3/4"	6"	10 15/16"	3 1/4"	1 1/4"	-215	1 1/2"	2.156	18 3/4 lb.

C-M-1400 Stepped Mandrels

Between center mandrel to accommodate shorter bore lengths and light manufacturing operations.

.001" T.I.R.					
Mandrel No. C-M	A Expansion	B	C	D	Total Weight
1401	1/2-1"	9 1/4"	3 1/4"	3	3/4 lb.
1402	1-1 1/2"	10 1/2"	4"	2	3 lb.
1403	1 1/2-2"	12"	4 3/4"	2	6 lb.
1404	2-3"	17"	7"	2	15 lb.
1405	3-4"	17"	7"	2"	35 lb.

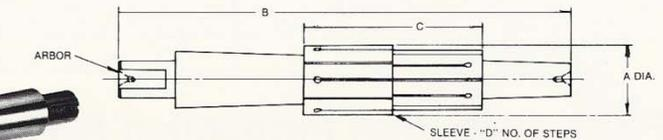

C-M-1403 Mandrel

C-M-140 Wide Range Mandrels

Between center mandrel where maximum expansion is required to accommodate wide variation of part bore sizes.

.001" T.I.R.				
Mandrel No. C-M	A Expansion	B	C	Total Weight
140	3/8-1/2"	4 1/2"	1 1/4"	1/8 lb.
141	1/2-11/16"	5 3/4"	1 1/2"	1/4 lb.
142	11/16-1"	9 1/4"	2 1/2"	1 1/4 lb.
143	1-1 9/16"	12 1/4"	3 1/4"	2 3/4 lb.
144	1 9/16-2 1/2"	16 3/4"	4 1/4"	8 1/2 lb.
145	2 1/2-3 1/4"	17 3/4"	7"	17 3/4 lb.
146	3 1/4-4"	18"	7"	30 lb.



C-M-143 Mandrel

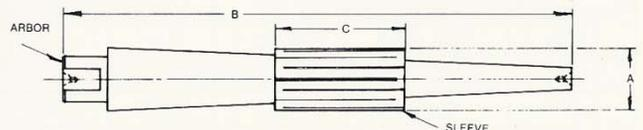



F-N/P-800 Flange-Mounted Mandrels

More mounting holes, larger flange and shorter overall length add user flexibility. Nut or power drawbar actuation. Two sleeve styles available. F-N-800 operates manually; F-P-800 accepts only power drawbar. F-N-800 includes arbor, sleeve, drawbar, nut, washer; F-P-800 includes arbor, sleeve, drawbar, and washer.

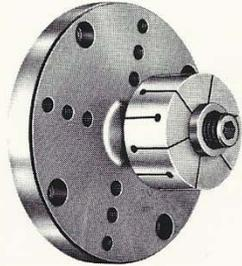

F-N-806 Mandrel

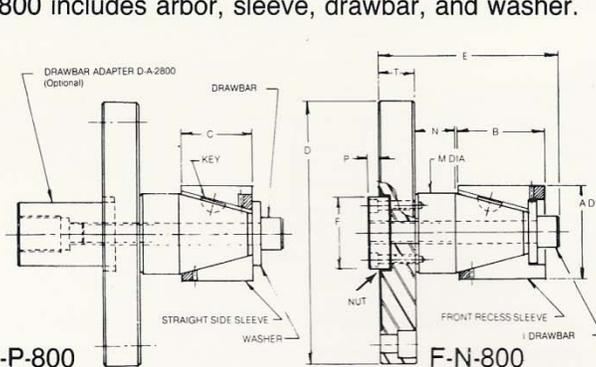

F-P-800

F-N-800

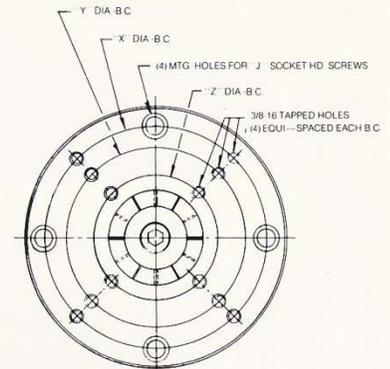

Mandrel No. F-N/P	A	Front Recess B	Straight Side C	D	E	F	J	M	N	P	T	X	Y	Z	Total Weight
803	7/8-1 1/2	31/32	3/4	4 7/8	2 1/2	1 1/2	5/16	11/16	11/16	0	5/8	4	N/A	2	3 3/4
804	1 1/8-2	1 1/8	7/8	4 7/8	2 7/8	1 1/2	5/16	7/8	7/8	3/32	5/8	4	N/A	2	4
805	1 1/2-3	1 17/32	1 1/4	5 5/8	3 3/4	1 1/2	3/8	1 1/4	1 1/8	7/32	3/4	5	3 3/4	2 1/2	7 3/4
806	1 7/8-4 1/4	1 31/32	1 5/8	5 7/8	4 1/4	1 1/2	3/8	1 1/2	1 1/8	7/32	3/4	5	3 3/4	2 1/2	10 1/2
807	2 5/8-5 1/2	2 15/32	2	7 3/8	5	2	1/2	2 1/4	1 1/8	9/32	1	6 1/4	5	3 1/2	21 1/4
808	3 3/8-6 1/2	2 27/32	2 1/4	8 3/8	5 1/2	2	1/2	2 3/4	1 1/8	7/32	1	7 1/4	5 3/4	4 1/4	44 3/4
809	4 1/4-8	3 17/32	2 3/4	8 7/8	8 3/8	2	5/8	3 3/4	1 1/8	0	1 1/4	7 1/2	6 1/4	5	76 1/2

ORDERING REQUIREMENTS:

1. Specify bore diameter and tolerance
2. Power or nut operation
3. Sleeve style

F-N/P-1800 High Production Flange-Mounted Mandrels

Two sleeve styles available. Unique six hole design accommodates both three and four hole mounting requirements. F-P-1800 accepts only power drawbar; F-N-1800 operates manually. Both F-P-1800 and F-N-1800 Series Mandrels consist of arbor, sleeve, drawbar and washer.



F-N-1807 Mandrel

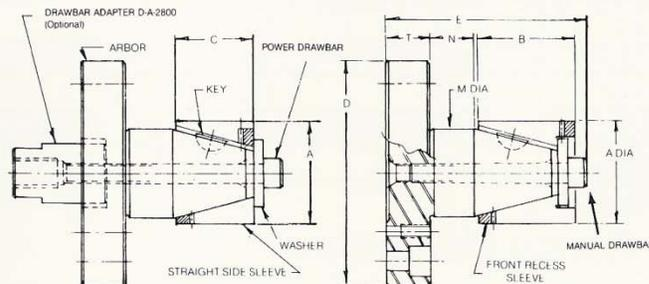

F-P-1800

F-N-1800

Mandrel No. F-N/P	A	Front Recess B	Straight Side C	D	E	J	K	L	M	T	N	Total Weight
1803	7/8-1 1/2"	31/32"	3/4"	4 1/4"	2 3/4"	3/8"	3 1/4"	2"	11/16"	7/8"	11/16"	4 lb.
1804	1 1/8-2"	1 1/8"	7/8"	4 1/4"	3 1/8"	3/8"	3 1/4"	2"	7/8"	7/8"	7/8"	4 1/4 lb.
1805	1 1/2-3"	1 17/32"	1 1/4"	4 1/4"	4"	3/8"	3 1/4"	2"	1 1/4"	1"	1 1/8"	6 lb.
1806	1 7/8-4 1/4"	1 31/32"	1 5/8"	5 3/4"	4 5/8"	1/2"	4 1/2"	3 1/8"	1 1/2"	1 1/8"	1 1/8"	13 lb.
1807	2 5/8-5 1/2"	2 15/32"	2"	5 3/4"	5 1/8"	1/2"	4 1/2"	3 1/8"	2 1/4"	1 1/8"	1 1/8"	18 1/2 lb.
1808	3 3/8-6 1/2"	2 27/32"	2 1/4"	7 1/4"	5 5/8"	1/2"	6"	4 1/2"	2 3/4"	1 1/8"	1 1/4"	42 1/4 lb.
1809	4 1/4-8"	3 17/32"	2 3/4"	7 1/4"	6 1/4"	1/2"	6"	4 1/2"	3 3/4"	1 1/8"	1 1/8"	67 3/4 lb.

ORDERING REQUIREMENTS:

1. Specify bore diameter and tolerance
2. Power or nut operation
3. Sleeve style



D-A-2800 Drawbar Adapters

D-A-2800 Drawbar Adapter allows one power drawbar to accommodate various mandrel sizes, simplifying set up.

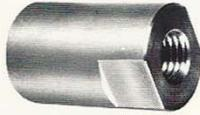

D-A-2807

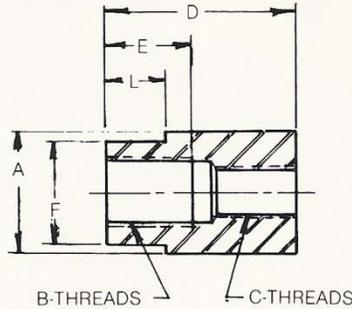
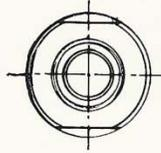

D-A-No.	A	B	C	D	E	F	L	Used with 800 Series	Used with 1800 Series
2803	1¼	3/4-10	1/4-20	2¾	1⅛	1⅛	¾	803	1803
2804	1¼	3/4-10	5/16-18	2¾	1⅛	1⅛	¾	—	1804
2805	1¼	3/4-10	3/8-16	2¾	1⅛	1⅛	¾	804	1805
2806	1½	3/4-10	1/2-13	2¾	1⅛	1¼	¾	805, 806	1806
2807	1¾	1-8	5/8-11	2¾	1¼	1½	7/8	807	1807
2808	1¾	1-8	3/4-10	2¾	1¼	1½	7/8	808	1808

F-B-A-3800 Flat Back Adapters

P-L-4800 Part Locators

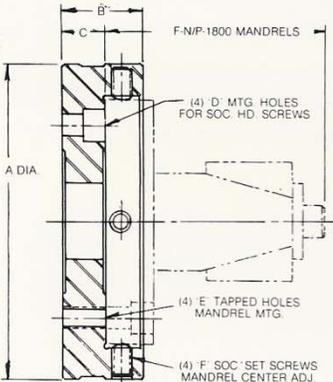

F-B-A-3806

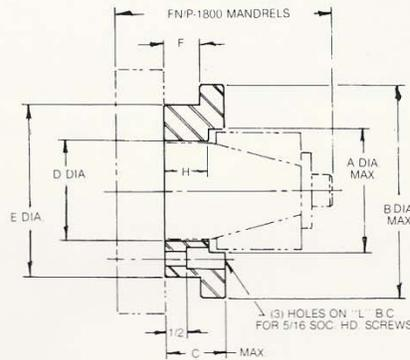

P-L-4807

F-B-A-3800 Series Flat Back Adapter permits easier 1800 mandrel set up through use of centering screws.

P-L-4800 Part Locator helps position part economically and accurately on 1800 Series Mandrels.

F-B-A No.	Used with Mandrel Nos.	A	B	C	D	E	F
3803	1803-04-05	5⅝"	1½"	¾"	3/8"	3/8-16"	3/8"
3806	1806-07	7⅜"	1⅞"	1"	1/2"	1/2-13"	1/2"
3808	1808-09	8⅞"	1⅞"	1"	1/2"	1/2-13"	1/2"

P-L No.	A*	B*	C*	D	E	F	H	L	Used with
4803	1⅝"	4¼"	1⅛	¾"	2⅞"	7/16"	9/16"	2"	1803
4804	2⅛"	4¼"	1⅝	15/16"	2⅞"	1/2"	¾"	2"	1804
4805	3⅛"	4¼"	1¾"	1⅝	2⅞"	13/16"	1⅛	2"	1805
4806	4⅝"	5¾"	1⅝	1⅞	4"	13/16"	1⅛	3⅛"	1806
4807	5⅝"	6¼"	2⅛"	2⅝	4"	13/16"	1⅛	3⅛"	1807
4808	6⅝"	7¼"	2¼"	2⅜	5⅞"	13/16"	1⅛	4½"	1808
4809	8⅛"	9¼"	2½"	3⅜	5⅞"	13/16"	1⅛	4½"	1809

*CUSTOMER TO SPECIFY A, B & C DIMENSIONS AT ORDER. Designs subject to change without notice.

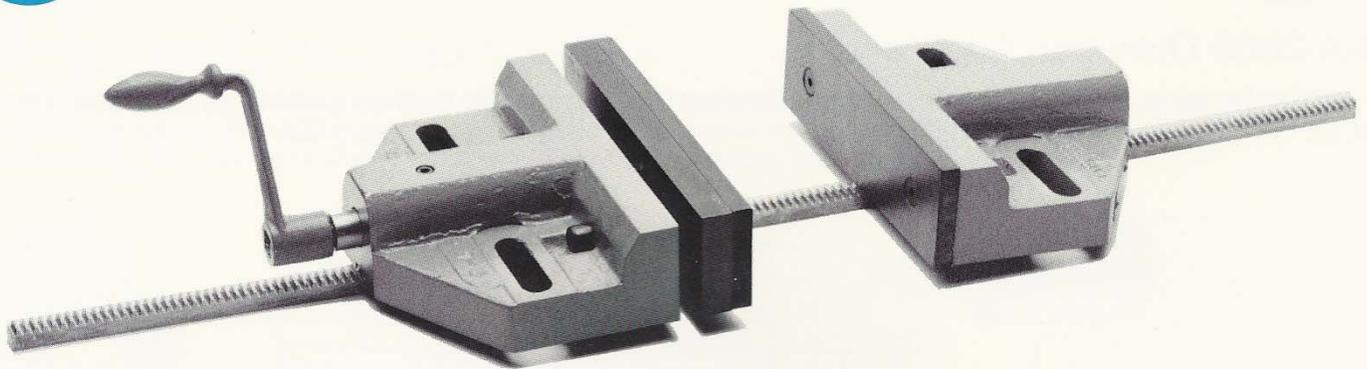

CHAMPION® SPLIT VISE

- Holds parts up to 61¾" long for machining on T slot tables with ½" or wider T slots.
- Unique tie bar gear rack withstands full clamping force.
- Heavy Acme screw allows 1" jaw movement.
- Jaws are hardened and ground steel.
- Vise always aligns with T slots.
- Easy to adjust for length

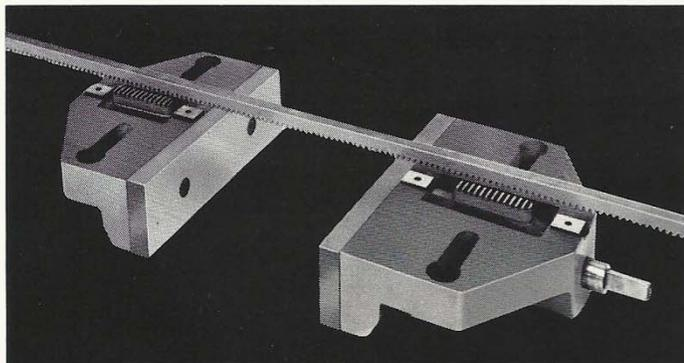

Catalog # CSV-9	
Jaw Width	9"
Jaw Movement with Acme Screw	1"
Jaw Opening with 36" Tie Bar	25¾"
Jaw Opening with 72" Tie Bar	61¾"
Jaw Height	2½"
Weight	58 pounds

Shipped with 36" tie bar (CSV-9-36) and four "T" slot keys (specify size). Also 72" tie bar available for longer tables.

CHAMPION® SWIVEL JAWS

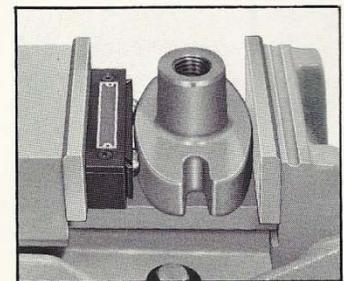
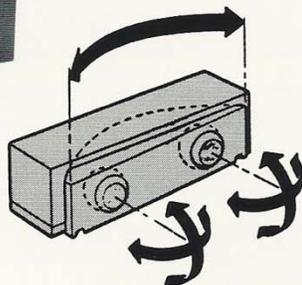

- Mounts in any standard vise
- Eliminates shims and fixtures for irregular, curved, or tapered work.
- Automatic compensation for irregular shapes.
- Reduces part damage.
- Increases vise life.
- Improves cutting tool life.

Swivel Jaw Catalog #	SJ-25	SJ-45	SJ-55	SJ-65
Overall Length	2½"	4½"	5½"	6½"
Overall Depth	1 ⁹ / ₃₂ "	1 ⁵ / ₁₆ "	1 ¹¹ / ₁₆ "	1 ¹³ / ₁₆ "
Overall Height	1 ⁵ / ₁₆ "	1 ⁵ / ₁₆ "	1½"	1½"
Distance Between Balls	7 ⁸ / ₈ "	2¼"	3¼"	5"
Block and Base Swivel Angle	13½°	7½°	6°	5°
Weight (pounds)	1	2	4	5



CHAMPION® SHAFT FIXTURES

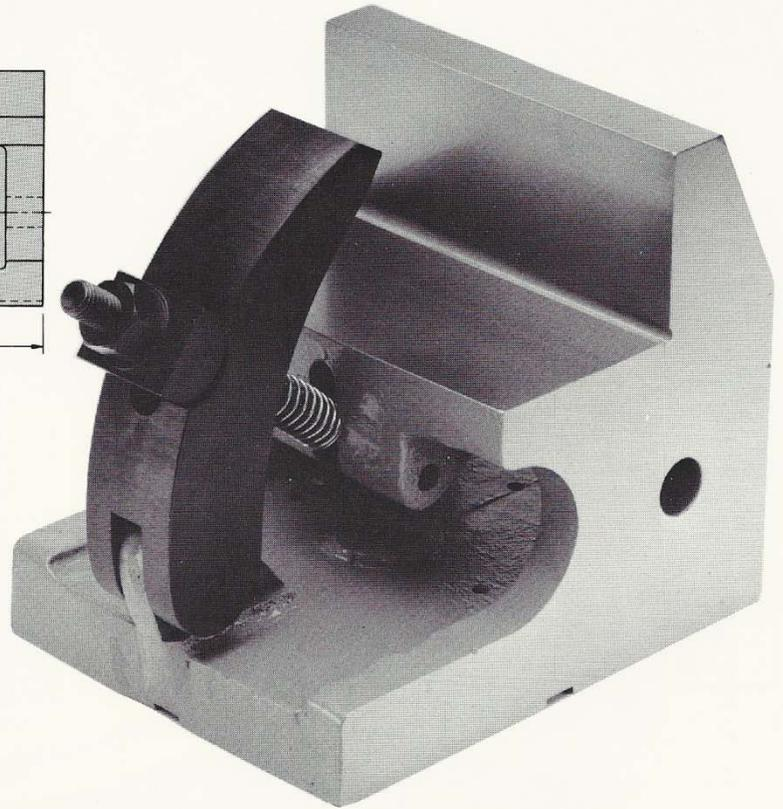
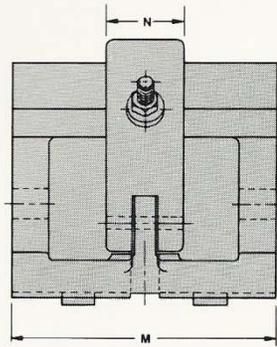
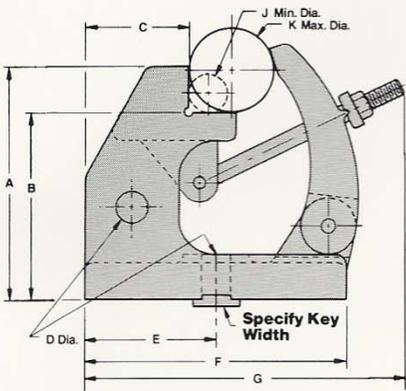

- An essential investment for round, square, hexagonal, octagonal, or rectangular shafting.
- Key in fixture base aligns work with T slots in table.
- All working surfaces precision ground.
- Available in matched sets for longer work.
- Can be used vertically or horizontally.
- Comes in four sizes.

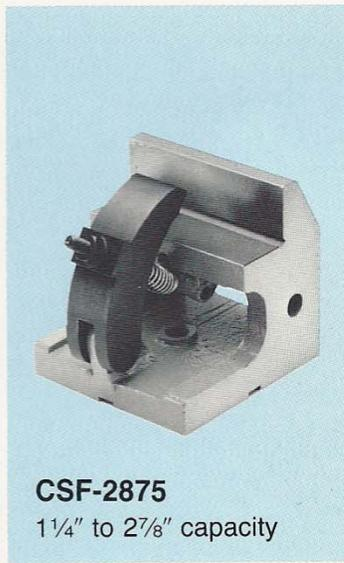
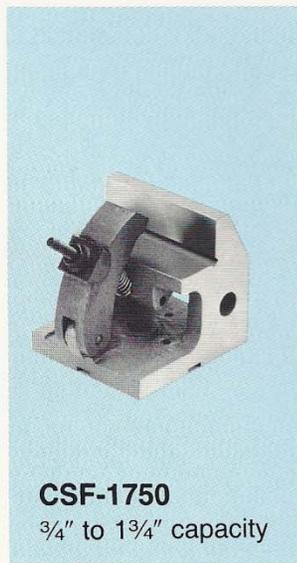

Catalog #	Dimension Code											Weight (lbs)
	A	B	C	D	E	F	G	J	K	M	N	
CSF-1125	3 1/8	2 1/2	1 3/8	9/16	1 3/4	3 1/2	4 1/4	1/2	1 1/8	3 1/2	1 1/16	6
CSF-1750	4 3/16	2 15/16	1 7/16	1 1/16	2 3/16	4 3/8	5 1/2	3/4	1 3/4	4	1 1/8	8
CSF-2875	5 5/8	4	1 5/8	1 1/16	2 7/8	5 3/4	7 3/8	1 1/4	2 7/8	5 1/2	1 1/2	18
CSF-4500	7 1/4	4 5/8	2 1/16	1 3/16	4	8	10	2 1/2	4 1/2	6 1/2	1 5/8	44



CHAMPION® SUPER "V" BLOCKS

Catalog # CSVB-612

- 4" to 18" shaft capacity.
- Adjustable roller chain strap simplifies setup.
- Aligns work quickly with machine table.
- Sold in sets of two — total weight 100 pounds.

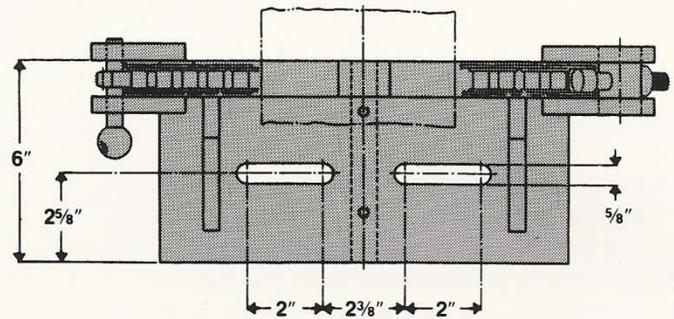
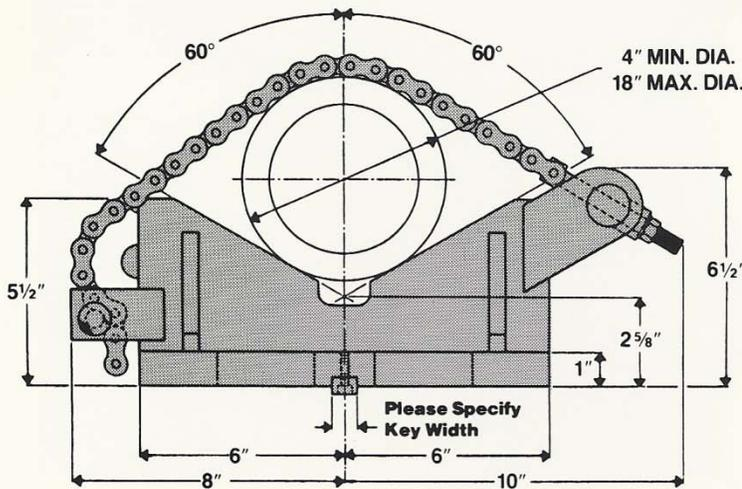
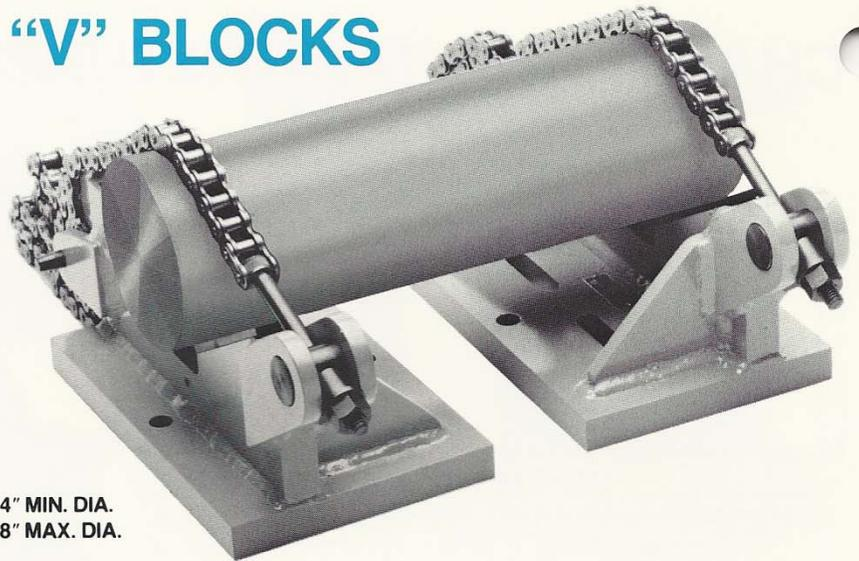

OTHER PRECISION DEVICES PRODUCTS

BALL ARBORS AND CHUCKS



SURFOMETER® SURFACE ROUGHNESS AND PROFILE MEASURING SYSTEMS



FOR INFORMATION,
CONTACT:



PRECISION DEVICES, INC.

606 County Street, P.O. Box 220, Milan, Michigan 48160-0220
(734) 439-2462 FAX: (734) 439-1461 Email: sales@predev.com